

### Advantages:

- high quality XLamp power LED of CREE Lighting,
- operating current up to 700 mA,
- safe low operating voltage,
- wide range of available colours.

### Applications:

- general illumination,
- mobile light sources (e.g. flash lights),
- traffic lights,
- decorative and accenting illumination.

### Technical data<sup>1)</sup>

LED Module	Colour	Number of LED	Advisable power supply	Operating voltage [V]		Operating current [mA]	Power [W]	Viewing angle <sup>2)</sup> [°]	Wavelength [nm]	Luminous flux [lm]	Luminous flux [lm]
				min	max						
m-LUMO XR ROY	Royal blue	1	Current	3,4	4	700	2,6	100	460	255 mW	380 mW
m-LUMO XR BLU	Blue	1	Current	3,4	4	700	2,6	100	470	15	25
m-LUMO XR CYN	Cyan	1	Current	3,4	4	700	2,6	100	505	45	76
m-LUMO XR GRN	Green	1	Current	3,4	4	700	2,6	100	525	52	88
m-LUMO XR AMB	Amber	1	Current	2,3	3	350	0,9	100	590	42	42
m-LUMO XR RDO	Red - Orange	1	Current	2,3	3	700	1,7	100	615	49	83
m-LUMO XR RED	Red	1	Current	2,3	3	700	1,7	100	630	40	68

<sup>1)</sup> All data concern particular module. Values of each parameters are average values and in particular copy they can be differ than in the table above.

<sup>2)</sup> Maximum angle at which LED intensity value is 50% of maximum intensity, observed at mechanical axis of LED.

### Qualities:

- the highest light efficiency,
- small footprint (d = 20mm),
- dimensions adapted to many types of optics,
- easy to montage,
- great thermal flow thanks to innovative thermal vias technology,
- high quality, brand name product.

## Tolerated work parameters<sup>1)</sup>

LED Module	Operating temperature [°C]		DC voltage [V]	Reverse voltage [V]	Junction temperature [°C]
	min	max	max	max	max
m-LUMO XR ROY	-40	85	4	5	145
m-LUMO XR BLU	-40	85	4	5	145
m-LUMO XR CYN	-40	85	4	5	145
m-LUMO XR GRN	-40	85	4	5	145
m-LUMO XR AMB	-40	85	3	5	145
m-LUMO XR RDO	-40	85	3	5	145
m-LUMO XR RED	-40	85	3	5	145

<sup>1)</sup> Table of physical work parameters, that must not be exceeded because of possibility of lifetime reduction or permanent damage of LED module.

## Drawing and mechanical dimensions

Shape round

Dimensions diameter 20mm, substrate thickness 1mm

Hight 5,4mm

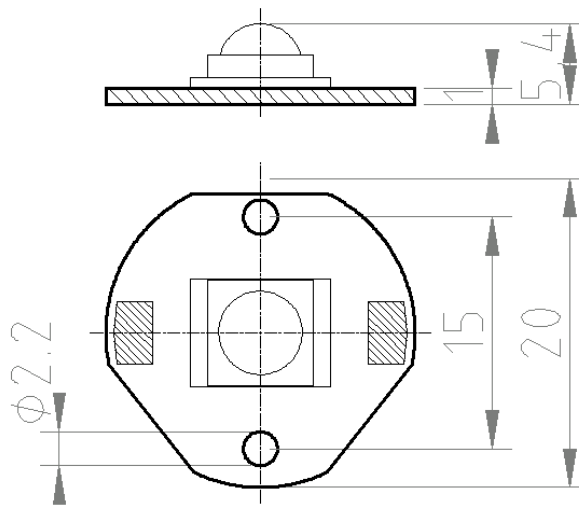

Fig. 1. m-LUMO XR.

## Safety information

1. Modules must not be weighed down mechanically to work safely.
2. Montage elements must not destroy LEDs or paths on the plate.
3. Modules have no short circuit, overcharge and thermal protection. It is absolutely necessary for LED power circuits to have such protections.
4. Modules installation (with driving circuits) must be in accordance with all electric and safe standards.
5. It is necessary to keep proper polarization of driving voltages. Wrong polarization could cause LED damage.
6. During installation it is important to remember about influence of electrostatic charge. Before installation charges should be neutralized by touching metal parts of grounded elements (e.g. copper pipe, tap, etc.).
7. It is recommended to keep chip temperature below 85°C. In order to draw heat away from LED junction external radiators can be used. Parameters and dimensions of radiator can be computed using proper equations. Each application, depending on number of LEDs, power, montage and many other parameters, need to be processed separately. LEDIKO provides optimal solutions for each customer.
8. LEDs have not corrosion resistant elements. User should provide safe work conditions of circuit. LEDIKO products do not fall within complaint on the basis of damages caused by humidity and chemical conditions.
9. LEDIKO modules are not appropriate to use direct outdoor or in conditions that may damage electric parts (e.g. low or high temperature, humidity, chemical conditions). In such applications it is necessary to use special packages.
10. Package should fulfil such requirements:
  - optical transparency from light emitted side,
  - UV protection (in case of sun light exposure),
  - drawing heat away, to keep safe work of circuit,
  - heat produced by LED resistance,
  - low transmission in all climate conditions.

## Montage information

1. LED modules must be connected to power supply in accordance with all electric and safe standards. Before switching power on it is always required to check all the electric connections and make sure that power supply has proper electric parameters.
2. It is very important to mount module to the element which helps to draw heat away (e.g. aluminium plate, radiator). In case of montage using screws, some separators (silicone, mica, silicone paste or other material that conduct heat) are needed between radiator and substrate of the module. Such a separator needs to be used, because it helps to transfer heat from the substrate to the radiator and makes LED work conditions better. Module can also be mounted to the radiator using special glue or tape, which conduct heat.
3. Depends on the power of power supply it is important to use radiator with proper thermal resistance. When power supply is 1W, radiator should have maximum thermal resistance at a level of 30 K/W, it corresponds e.g. aluminium sheet, 2 mm thickness and 16cm<sup>2</sup> area (e.g. 4 cm side square).  
When power supply is 3W, radiator should have maximum thermal resistance at a level of 7 K/W, it corresponds e.g. aluminium sheet, 2 mm thickness and 100cm<sup>2</sup> area (e.g. 10 cm side square).
4. m-LUMO XR LED module has 4 big electric pads. Each electrode '+' and '-' has two pads, where positive and negative voltage should be connected. Each of additional pads help to connect LED modules parallel. To solder cables, standard soldering gun is needed.
5. There are examples of m-LUMO XR connections on the next page. It is recommended to drive modules by current, using special current power supplies (example number 2). It is possible to drive modules by voltage using stabilized voltage power supplies with serial resistor (example number 1) or LM317 circuit in current stabilization mode (example number 3). m-LUMO XR modules are adjustable to connecting them parallel (example number 4).
6. Shown schemes are not all possible ways of connecting, they only illustrate how m-LUMO XR modules can be driven. To get more information about LED driving please visit our web page [www.lediko.com](http://www.lediko.com) and see section [Technology](#).

## Typical connections

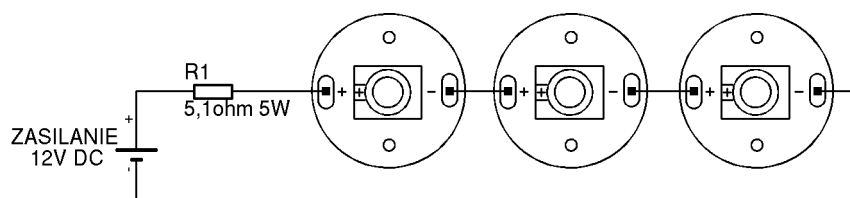

Fig. 2. Three serial connected m-LUMO XR modules, drive voltage 12 V.

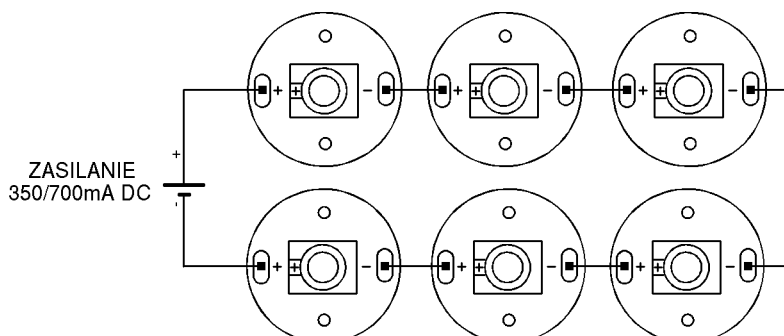

Fig. 3. Six m-LUMO XR modules, drive current 350/700 mA.

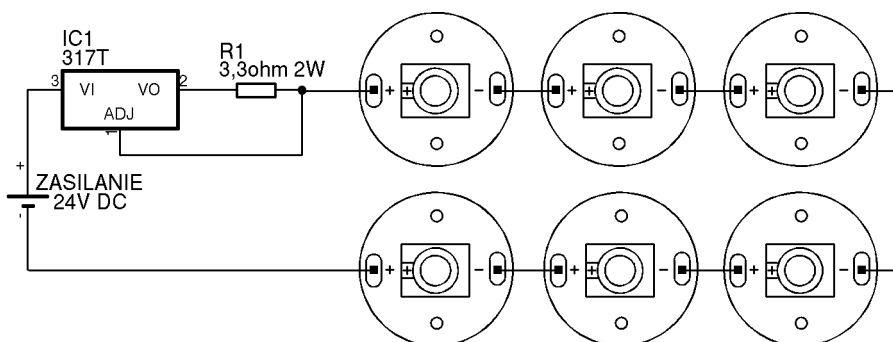

Fig. 4. Parallel connection of m-LUMO XR modules, drive voltage 24 V.

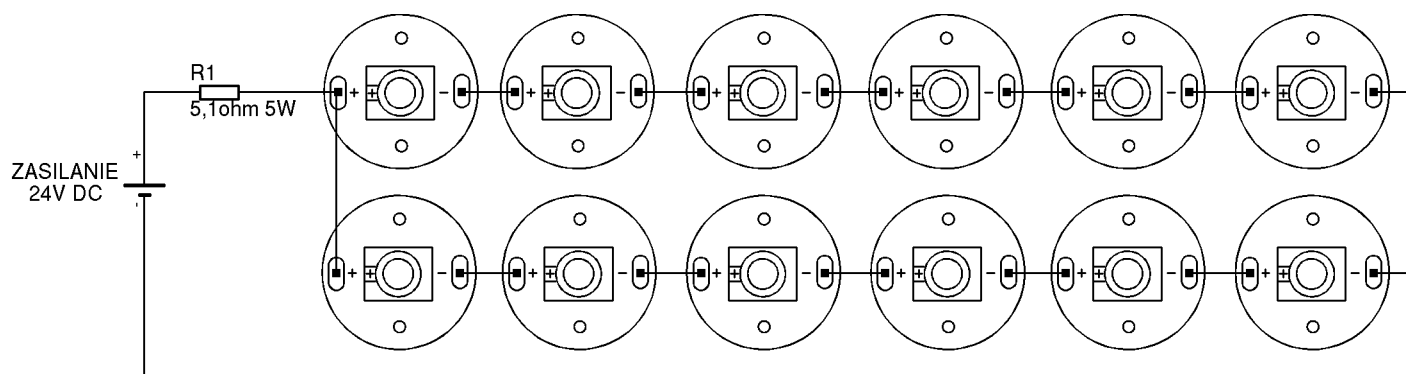

Fig. 5. Parallel connection of m-LUMO XR modules, drive voltage 24 V.

**Notice:** Values of resistors are selected in a way to achieve 1 W of power on each LED (3,4 V 350 mA). These circuits cannot be used with modules with amber, orange and red colour of LED, because of different drive voltage in those LEDs.

## Order particulars

LED Module	Colour	Wavelength	Typ. luminous flux (350mA)
m-LUMO XR ROY	Royal blue	460 nm	255 mW
m-LUMO XR BLU	Blue	470 nm	15 lm
m-LUMO XR CYN	Cyan	505 nm	45 lm
m-LUMO XR GRN	Green	525 nm	52 lm
m-LUMO XR AMB	Amber	590 nm	42 lm
m-LUMO XR RDO	Orange - Red	615 nm	49 lm
m-LUMO XR RED	Red	630 nm	40 lm

### When placing an order please write:

- 1) Name and surname of orderer,
- 2) Company name,
- 3) Company Tax Identification Number,
- 4) Address of company or private address for individual customers,
- 5) City and post code,
- 6) Index of elements: number of elements, product code,
- 7) Sending address (if differ from company address).

**Welcome to contact us and place orders.**

**Phone: +48 71 79 85 785**

**[www.lediko.com](http://www.lediko.com)**

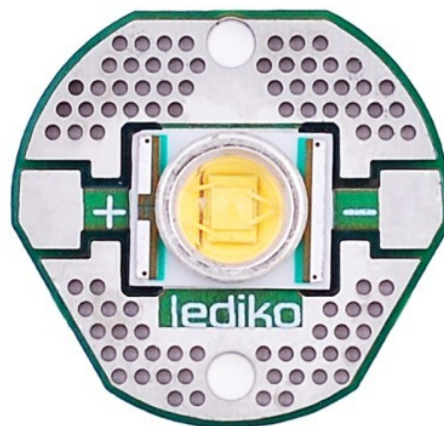

Notice: "LEDIKO Walendowski i Wilanowski" Sp.J. stipulate the information in this document is subject to change without notice.