

Data Sheet
STAR-XR
LED Module

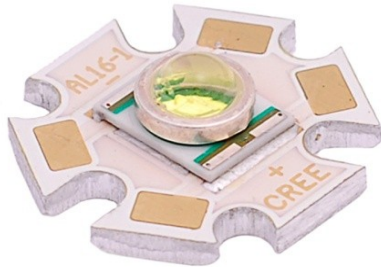

Advantages:

- high quality XLamp power LED of CREE Lighting,
- compact dimensions: diameter 20mm,
- safe low operating voltage,
- easy and convenient to install,
- universal star shape radiator,
- wide range of available colours.

Applications:

- general illumination,
- mobile light sources (e.g. flash lights),
- traffic lights,
- decorative and accenting illumination.

Technical data¹

LED Module	Colour	Number of LEDs	Advisable power type	Typical operating voltage		Typical operating current [mA]	Power [W]	Viewing angle ²⁾ [°]	Wavelength [nm]	Luminous flux [lm]	Luminous flux [lm]
				min	max						
				typ.	typ. (I = 350mA)	typ. (I = max)					
STAR XR ROY	Royal blue	1	Current	3,4	4	700	2,6	100	460	255 mW	380 mW
STAR XR BLU	Blue	1	Current	3,4	4	700	2,6	100	470	15	25
STAR XR CYN	Cyan	1	Current	3,4	4	700	2,6	100	505	45	76
STAR XR GRN	Green	1	Current	3,4	4	700	2,6	100	525	52	88
STAR XR AMB	Amber	1	Current	2,3	3	350	0,9	100	590	42	42
STAR XR RDO	Orange Red	1	Current	2,3	3	700	1,7	100	615	49	83
STAR XR RED	Red	1	Current	2,3	3	700	1,7	100	630	40	68

¹⁾All data concern particular module. Values of each parameters are average values and in particular copy they can be differ than in the table above. Correlated colour temperature and wavelength have been defined by range, which contains this value.

²⁾Maximum angle at which LED intensity value is 50% of maximum intensity, observed at mechanical axis of LED.

Qualities:

- small footprint (d = 20mm),
- great thermal flow thanks to innovative thermal vias technology,
- modules optimized to driving by impulse constant current power supplies,
- possibility of brightness regulation thanks to PWM with drivers produced by LEDIKO,
- light is emitting orthogonally to plate surface.

Tolerated work parameters*

LED Module	Operating temperature [°C]		Voltage DC [V]	Reverse voltage [V]	Junction temperature [°C]
	min	max	max	max	max
STAR XR ROY	-40	85	4	5	145
STAR XR BLU	-40	85	4	5	145
STAR XR CYN	-40	85	4	5	145
STAR XR GRN	-40	85	4 </td <td>5</td> <td>145</td>	5	145
STAR XR AMB	-40	85	3	5	145
STAR XR RDO	-40	85	3	5	145
STAR XR RED	-40	85	3	5	145

*) Table of physical work parameters, that must not be exceeded because of possibility of lifetime reduction or permanent damage of LED module.

Drawing and mechanical dimensions

Shape star

Dimensions star made of regular hexagon (11,5 mm side length), substrate thickness 2 mm

Hight 6,3mm

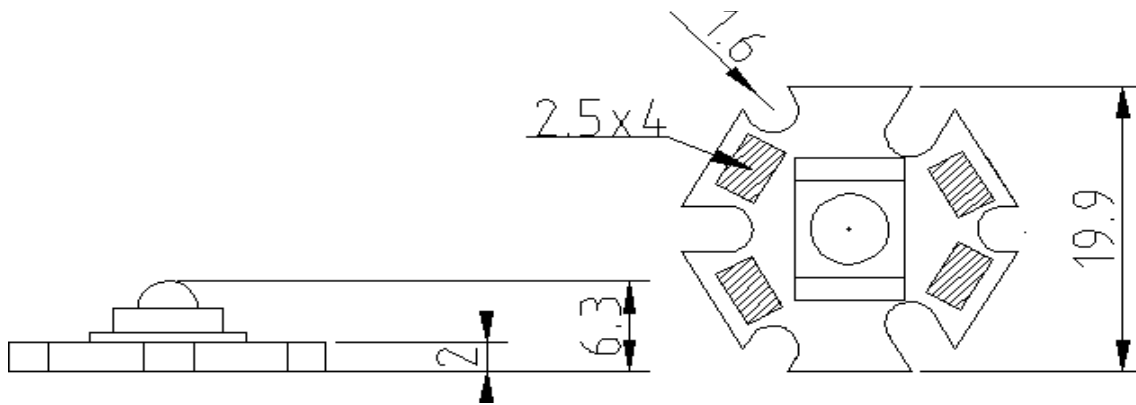

Fig.1. Mechanical dimensions of STAR XR module.

Safety information

1. Modules must not be weighed down mechanically to work safely.
2. Montage elements must not destroy LEDs or paths on the plate.
3. Modules have no short circuit, overcharge and thermal protection. It is absolutely necessary for LED power circuits to have such protections.
4. Modules installation (with driving circuits) must be in accordance with all electric and safe standards.
5. It is necessary to keep proper polarization of driving voltages. Wrong polarization could cause LED damage.
6. During installation it is important to remember about influence of electrostatic charge. Before installation charges should be neutralized by touching metal parts of grounded elements (e.g. copper pipe, tap, etc.).
7. It is recommended to keep chip temperature below 85°C. In order to draw heat away from LED junction external radiators can be used. Parameters and dimensions of radiator can be computed using proper equations. Each application, depending on number of LEDs, power, montage and many other parameters, need to be processed separately. LEDIKO provides optimal solutions for each customer.
8. LEDs have not corrosion resistant elements. User should provide safe work conditions of circuit. LEDIKO products do not fall within complaint on the basis of damages caused by humidity and chemical conditions.
9. LEDIKO modules are not appropriate to use direct outdoor or in conditions that may damage electric parts (e.g. low or high temperature, humidity, chemical conditions). In such applications it is necessary to use special packages.
10. Package should fulfil such requirements:
 - optical transparency from light emitted side,
 - UV protection (in case of sun light exposure),
 - drawing heat away, to keep safe work of circuit,
 - heat produced by LED resistance,
 - low transmission in all climate conditions.

Montage information

1. LED modules must be connected to power supply in accordance with all electric and safe standards. Before switching power on it is always required to check all the electric connections and make sure that power supply has proper electric parameters.
2. STAR-XR LED module has 4 big electric pads. Each electrode '+' and '-' has two pads, where positive and negative voltage should be connected. Each of additional pads help to connect LED modules parallel. To solder cables, standard soldering gun is needed.
3. It is very important to mount module to the element which helps to draw heat away (e.g. aluminium plate, radiator). In case of montage using screws, some separators (silicone, mica, silicone paste or other material that conduct heat) are needed between radiator and substrate of the module. Such a separator needs to be used, because it helps to transfer heat from the substrate to the radiator and makes LED work conditions better. Module can also be mounted to the radiator using special glue or tape, which conduct heat.
4. Depends on the power of power supply it is important to use radiator with proper thermal resistance. When power supply is 1W, radiator should have maximum thermal resistance at a level of 30 K/W, it corresponds e.g. aluminium sheet, 2 mm thickness and 16cm² area (e.g. 4 cm side square).
When power supply is 3W, radiator should have maximum thermal resistance at a level of 7K/W, it corresponds e.g. aluminium sheet, 2 mm thickness and 100cm² area (e.g. 10cm side square).
5. There are examples of STAR-XR connections on the following page. It is recommended to drive modules by current, using special current power supplies (Fig.2). It is possible to drive modules by voltage using stabilized voltage power supplies with serial resistor (Fig.1) or LM317 circuit in current stabilization mode (Fig.3). STAR-XR modules are adjustable to connecting them parallel (Fig.4).
6. Shown schemes are not all possible ways of connecting, they only illustrate how STAR-XR modules can be driven. To get more information about LED driving please visit our web page www.lediko.com and see section [Technology](#).

Typical connections

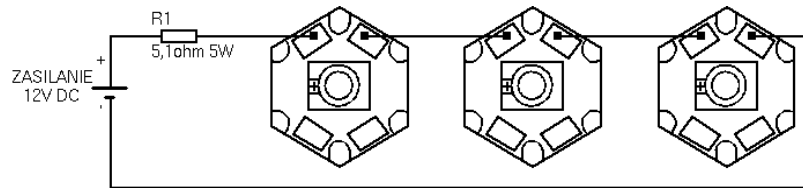

Fig.2. Three serial connected STAR-XR modules, drive voltage 12 V.

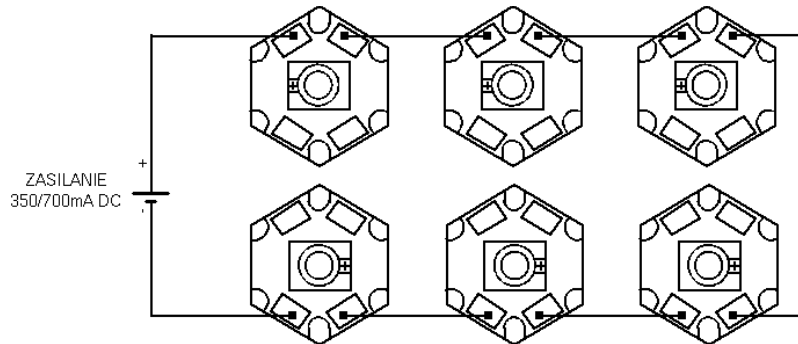

Fig.3. Six STAR-XR modules, drive current 350/700 mA.

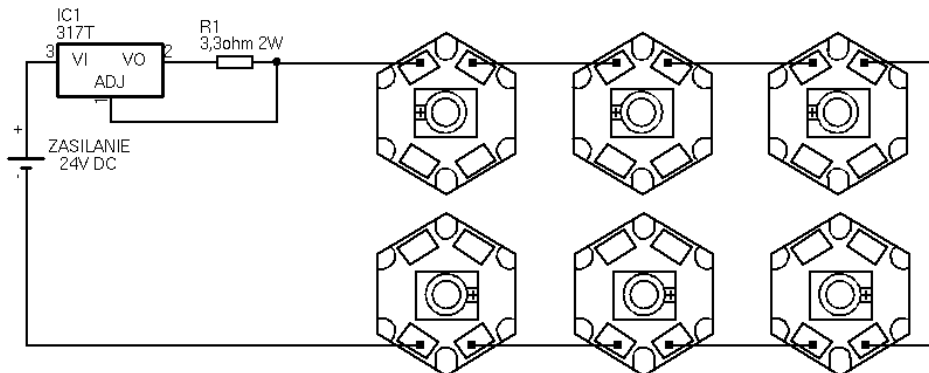

Fig.4. Six STAR-XR modules, drive voltage 24 V with LM317T stabilizer.

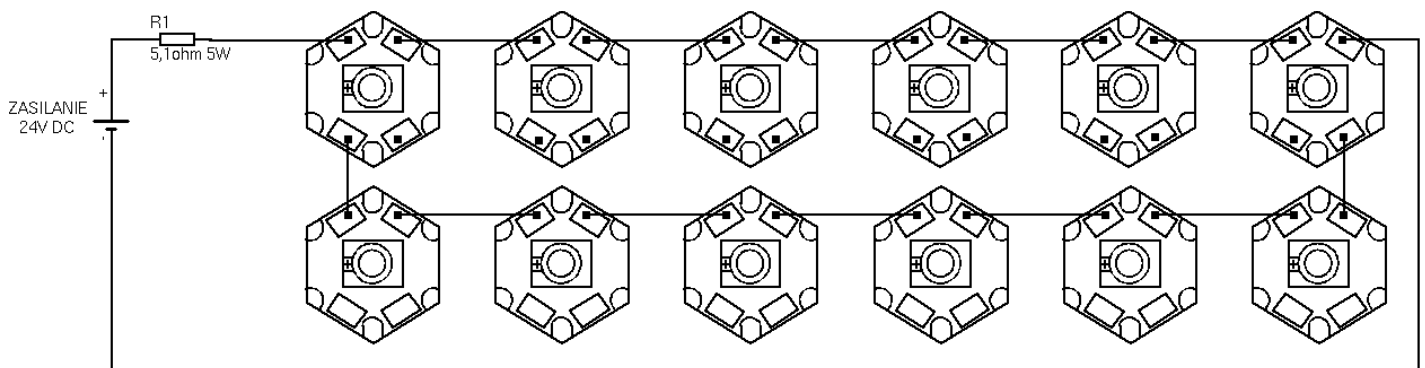

Fig.5. Parallel connection of STAR-XR modules, drive voltage 24 V.

Notice: Values of resistors are selected in a way to achieve 1 W of power on each LED (3,4 V 350 mA). These circuits cannot be used with modules with amber, orange and red colour of LED, because of different drive voltage in those LEDs.

Order particulars

LED Module	Colour	Wavelength	Typ. luminous flux (350mA)
STAR XR ROY	Royal blue	460 nm	255 mW
STAR XR BLU	Blue	470 nm	15 lm
STAR XR CYN	Cyan	505 nm	45 lm
STAR XR GRN	Green	525 nm	52 lm
STAR XR AMB	Amber	590 nm	42 lm
STAR XR RDO	Orange Red	615 nm	49 lm
STAR XR RED	Red	630 nm	40 lm

When placing an order please write:

- 1) Name and surname of orderer,
- 2) Company name,
- 3) Company Tax Identification Number,
- 4) Address of company or private address for individual customers,
- 5) City and post code,
- 6) Index of elements: number of elements, product code,
- 7) Sending address (if differ from company address).

Welcome to contact us and place orders.

Phone: +48 71 79 85 785

www.lediko.com



Notice: "LEDIKO Walendowski i Wilanowski" Sp.J. stipulate the information in this document is subject to change without notice.