

**Advantages:**

- high quality XLamp power LED of CREE Lighting,
- small footprint (**70 mm x 11 mm x 5,6 mm**),
- possibility of connecting modules in chains,
- safe low operating voltage,
- easy installation,
- wide range of available CCTs (from 2600 K up to 10000 K).

Applications:

- furniture and displays illumination,
- museum lightning,
- ceilings and parapets illumination,
- decorative and accenting illumination.

Technical data¹⁾

LED module	Colour	Number of LEDs	Advisable power type	Operating voltage		Operating current	Power	Viewing angle ²⁾	Correlated Colour Temperature	Luminous flux	Luminous flux
				[V]	[V]	[mA]	[W]	[°]	[K]	[lm]	[lm]
				min	max	max	max		typ.	typ. (I = 350mA)	typ. (I = max)
MEGA 1XR-E CW1	Cool white	1	Current	3,3	3,9	1000	4,0	90	6500	100	220
MEGA 1XR-E CW2	Cool white	1	Current	3,3	3,9	1000	4,0	90	6500	80	176
MEGA 1XR-E NW	Neutral white	1	Current	3,3	3,9	700	2,6	90	4300	74	126
MEGA 1XR-E WW	Warm white	1	Current	3,3	3,9	700	2,6	90	3000	67	114
MEGA 1XR-C CW	Cool white	1	Current	3,3	4	500	1,8	90	6500	62	90
MEGA 1XR-C NW	Neutral white	1	Current	3,3	4	500	1,8	90	4300	57	82
MEGA 1XR-C WW	Warm white	1	Current	3,3	4	500	1,8	90	3000	46	67

¹⁾All data concern particular module. Values of each parameters are average values and in particular copy they can be differ than in the table above.

²⁾ Maximum angle at which LED intensity value is 50% of maximum intensity, observed at mechanical axis of LED.

Qualities:

- no need to use additional radiator, when operating current is not bigger than 500mA (in common temperature),
- available to connect in serial - parallel chains,
- connection by solder pads or connectors,
- modules optimized to driving by impulse constant current power supplies,
- possibility of brightness regulation thanks to PWM with drivers produced by LEDIKO,
- light is emitting orthogonally to plate surface.

Tolerated work parameters¹⁾

LED module	Operating temperature [°C]		Voltage DC [V]	Reverse voltage [V]	Junction temperature [°C]
	min	max	max	max	max
MEGA 1XR-E CW1	-40	85	3,9	5	145
MEGA 1XR-E CW2	-40	85	3,9	5	145
MEGA 1XR-E NW	-40	85	3,9	5	145
MEGA 1XR-E WW	-40	85	3,9	5	145
MEGA 1XR-C CW	-40	85	4	5	145
MEGA 1XR-C NW	-40	85	4	5	145
MEGA 1XR-C WW	-40	85	4	5	145

¹⁾ Table of physical work parameters, that must not be exceeded because of possibility of lifetime reduction or permanent damage of LED module.

Drawing and mechanical dimensions

Shape: rectangular

Dimensions: length 70mm, width 11mm, substrate thickness 1,2mm

Height: 5,6mm

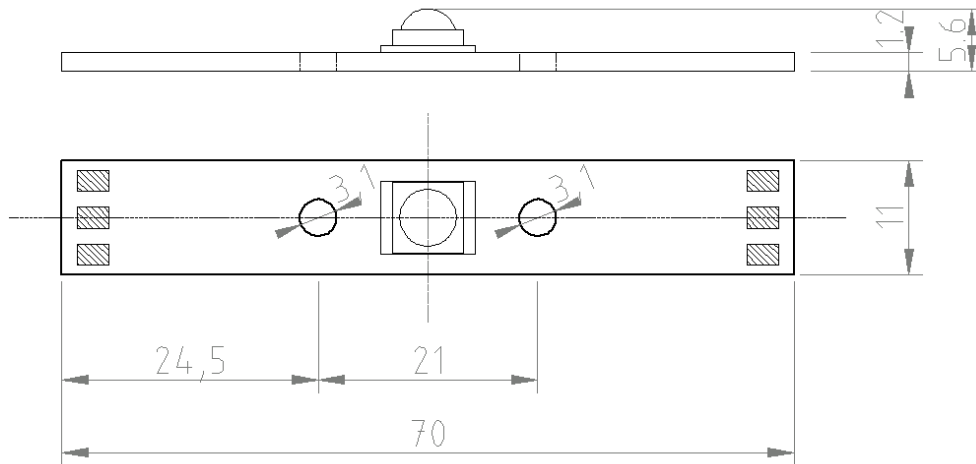

Fig. 1. MEGA 1XR module – basic version.

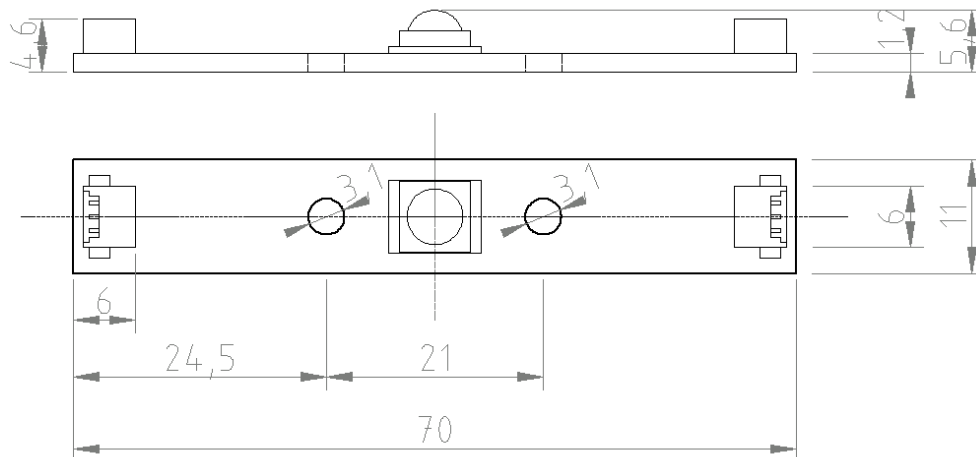

Fig. 2. MEGA 1XR module – version with connectors.

Safety information

1. Modules must not be weigh down mechanically to work safe.
2. Montage elements must not destroy LEDs or paths on the plate.
3. Modules have no short circuit, overcharge and thermal protection.
It is absolutely necessary for LED power circuits to have such protections.
4. Modules installation (with driving circuits) must be in accordance with all electric and safe standards.
5. It is necessary to keep proper polarization of driving voltages. Wrong polarization could cause LED damage.
6. During installation it is important to remember about influence of electrostatic charge. Before installation charges should be neutralized by touching metal parts of grounded elements (e.g. copper pipe, tap, etc.).
7. It is recommended to keep chip temperature below 85°C. In order to draw heat away from LED junction external radiators can be used. Parameters and dimensions of radiator can be computed using proper equations. Each application, depending on number of LEDs, power, montage and many other parameters, need to be process separately. LEDIKO provides optimal solutions for each customer.
8. LEDs have not corrosion resistant elements. User should provide safe work conditions of circuit. LEDIKO products do not fall within complaint on the basis of damages caused by humidity and chemical conditions.
9. LEDIKO modules are not appropriate to use direct outdoor or in conditions that may damage electric parts (e.g. low or high temperature, humidity, chemical conditions). In such applications it is necessary to use special package.
10. Package should fulfil such requirements:
 - optical transparency from light emitted side,
 - UV protection (in case of sun light exposure),
 - drawing heat away, to keep safe work of circuit,
 - heat produced by LED resistance,
 - low transmission in all climate conditions.

Mounting directions:

1. LED modules must be connected to power supply in accordance with all electric and safe standards. Before switching power on it is always required to check all the electric connections and make sure that power supply has proper electric parameters.
2. It is very important to mount module to the element which helps to draw heat away (e.g. aluminium plate, radiator). In case of montage using screws, some separators (silicone, mica, silicone paste or other material that conduct heat) are needed between radiator and substrate of the module. Such a separator needs to be used, because it helps to transfer heat from the substrate to the radiator and makes LED work conditions better. Module can also be mount to the radiator using special glue or tape, which conduct heat.
3. Depends on the power of power supply it is important to use radiator with proper thermal resistance. When power supply is lower than 1,5W, external radiator is not needed, but it can make lifetime of module longer. When power supply is 3W per LED, radiator should have maximum thermal resistance at a level of 7K/W, it corresponds e.g. aluminium sheet, 1-2 mm thickness and 100cm² area (e.g. 10cm side square).
4. Mount with two M3 screws (hole diameter ϕ 3,1mm), head diameter up to 6 mm. Between plate with LEDs and surface where module is mounted should be effective thermal contact. Module can also be mount to the surfacer using special glue or tape, which conduct heat.
5. Construction of MEGA 1XR modules let them to be connect in series or parallel. Connection is made by two wires (in serial or parallel connection) or by three wires in serial – parallel connection. There are some examples below.
6. When serial – parallel connection (Fig. 7) number of parallel connected modules must be not bigger than four (700mA operating current) or eight (350mA operating current). It is important to take into consideration resistance and maximum current of wires.

Connection details

MEGA 1XR module is available in four different configurations (depend on jumper placing, changing way of electrical connections on the board - Fig. 3).

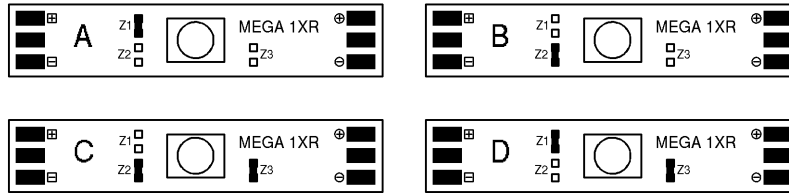

Fig. 3. Configuration of MEGA 1XR module.

Type A – module that begins series, connected to positive pole of power supply,

Type B – intermediate module, between beginning module (A) and ending module (C),

Type C – module that ends series, connected to negative pole of power supply,

Type D – module able to be connected direct to the power supply.



Fig. 4. Single module connected to current power supply (350/700mA) or voltage power supply (5V DC).



Fig. 5. Three modules connected to voltage power supply (12V DC).

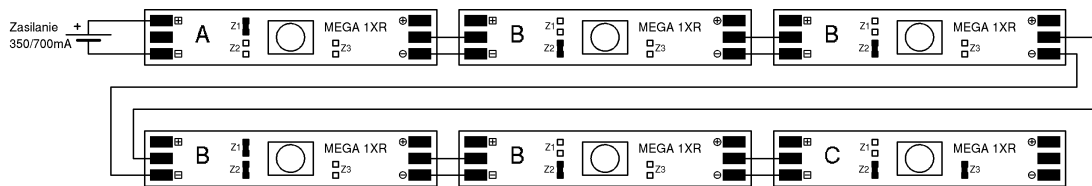

Fig. 6. Six modules connected to current power supply (350/700mA).

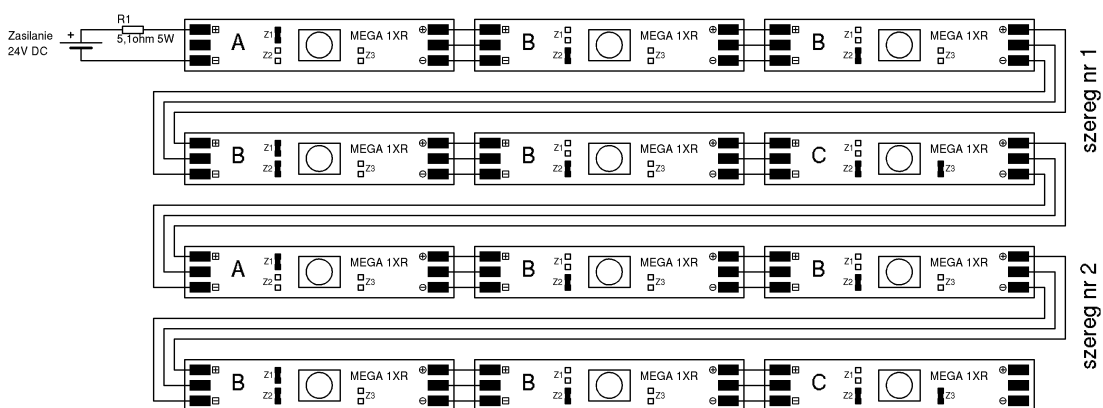

Fig. 7. Twelve modules connected to voltage power supply (24V DC).

Notice: Resistors values taken to achieve 1,2W of power per LED (3,3V 350mA).

Order particulars

LED module	Colour	Correlated Colour Temperature	Typ. luminous flux (350mA)
MEGA 1XR-E CW1	Cool white	6500 K	100 lm
MEGA 1XR-E CW2	Cool white	6500 K	80 lm
MEGA 1XR-E NW	Neutral white	4300 K	74 lm
MEGA 1XR-E WW	Warm white	3000 K	67 lm
MEGA 1XR-C CW	Cool white	6500 K	62 lm
MEGA 1XR-C NW	Neutral white	4300 K	57 lm
MEGA 1XR-C WW	Warm white	3000 K	46 lm

Order notices:

1. Jumpers are mounted following customer requirements.
2. Modules have aluminium or copper substrates. Copper substrate help to drawing heat away.
3. Standard module does not contains connectors. They are mounted following individual customer requiremets.

When placing an order please write:

1. Name and surname of orderer,
2. Company name,
3. Company Tax Identification Number,
4. Address of company or private address for individual customers,
5. City and post code,
6. Index of elements: number of elements, product code.

Welcome to contact us and place orders.

Phone: +48 71 79 85 785

www.lediko.com



Notice: "LEDIKO Walendowski i Wilanowski" Sp.J. stipulate the information in this document is subject to change without notice.