



lediko

Data Sheet

LUMO 1XR

Colour LED modules



Advantages:

- High quality XLamp 7090 power LED of CREE Lighting
- Operating current up to 700 mA
- Safe low operating voltage
- LED module adapted to wide range of optics
- Wide range of available colours

Applications:

- General illumination
- Mobile light sources (e.g. flash lights)
- Traffic lights
- Decorative and accenting illumination

Technical data¹

LED module	Colour	Advisable power type	Typical	Max. operating current ² [mA]	Max. power ² [W]	Viewing angle ³ [°]	Wavelength [nm]		Typical luminous flux [lm]
			operating voltage (350 mA) ² [V]				min.	max.	typ. (I = 350mA)
LUMO 1XR RY	Royal blue	Current	3,4	700	2,9	100	455	465	255mW
LUMO 1XR BLU	Blue	Current	3,4	700	2,9	100	465	475	19
LUMO 1XR CNY	Cyan	Current	3,4	700	2,9	100	500	510	45
LUMO 1XR GRN	Green	Current	3,4	700	2,9	100	520	535	52
LUMO 1XR AMB	Amber	Current	2,5	350	0,8	100	585	595	42
LUMO 1XR RDO	Orange - Red	Current	2,5	700	1,8	100	610	620	49
LUMO 1XR RED	Red	Current	2,5	700	1,8	100	620	635	40

¹All data concern particular module. Values of each parameters are average values and in particular copy they can be differ than in the table above. Correlated colour temperature and wavelength have been defined by range, which contains this value.

² Electrical values are effective values. It is recommended to power LEDs with direct voltage/current except PWM mode.

³ Maximum angle at which LED intensity value is 50% of maximum intensity, observed at mechanical axis of LED.

Qualities:

- the highest light efficiency,
- small footprint (d = 30mm),
- dimensions adapted to many types of optics,
- easy to montage,
- great thermal flow thanks to innovative thermal vias technology,
- high quality, brand name product.

Tolerated work parameters*

Product	Operating temperature [°C]		Max. voltage [V _{dc}]	Max. reverse voltage [V]	Max. junction temperature [°C]
	min.	max.			
LUMO 1XR RY	-40	85	4	5	145
LUMO 1XR BLU	-40	85	4	5	145
LUMO 1XR CYN	-40	85	4	5	145
LUMO 1XR GRN	-40	85	4	5	145
LUMO 1XR AMB	-40	85	3	5	145
LUMO 1XR RDO	-40	85	3	5	145
LUMO 1XR RED	-40	85	3	5	145

*) Table of physical work parameters, that must not be exceeded because of possibility of lifetime reduction or permanent damage of LED module.

Drawing and mechanical dimensions

Shape	round
Dimensions	diameter 30mm, substrate thickness 1mm
Hight	5,3mm

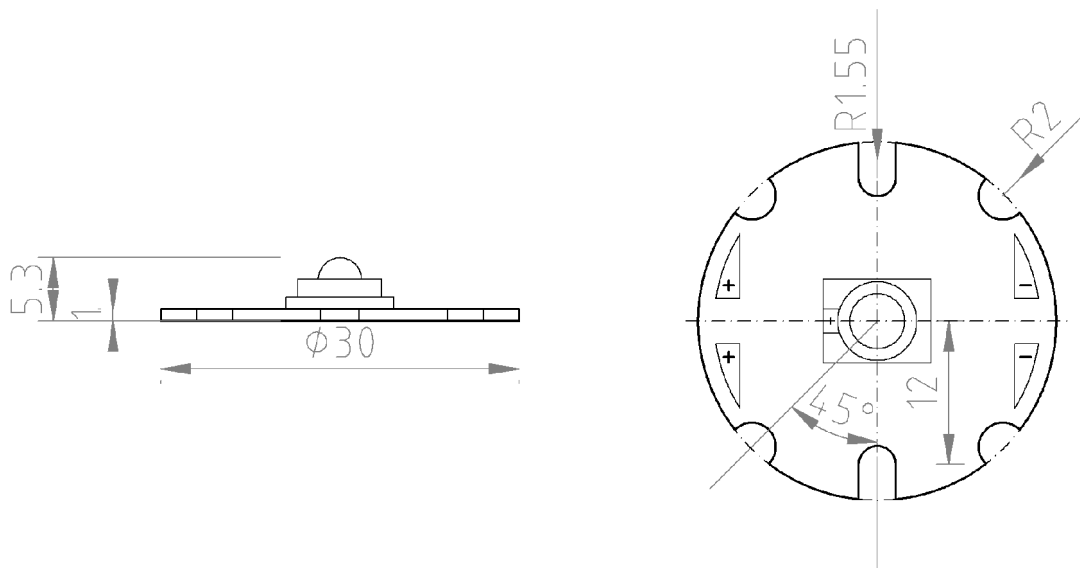

Safety information

1. Modules must not be weighed down mechanically to work safe.
2. Montage elements must not destroy LEDs or paths on the plate.
3. Modules have no short circuit, overcharge and thermal protection. It is absolutely necessary for LED power circuits to have such protections.
4. Modules installation (with driving circuits) must be in accordance with all electric and safe standards.
5. It is necessary to keep proper polarization of driving voltages. Wrong polarization could cause LED damage.
6. During installation it is important to remember about influence of electrostatic charge. Before installation charges should be neutralized by touching metal parts of grounded elements (e.g. copper pipe, tap, etc.).
7. It is recommended to keep chip temperature below 85°C. In order to draw heat away from LED junction external radiators can be used. Parameters and dimensions of radiator can be computed using proper equations. Each application, depending on number of LEDs, power, montage and many other parameters, need to be processed separately. LEDIKO provides optimal solutions for each customer.

8. LEDs have not corrosion resistant elements. User should provide safe work conditions of circuit. LEDIKO products do not fall within complaint on the basis of damages caused by humidity and chemical conditions.
9. LEDIKO modules are not appropriate to use direct outdoor or in conditions that may damage electric parts (e.g. low or high temperature, humidity, chemical conditions). In such applications it is necessary to use special packages.
10. Package should fulfil such requirements:
 - optical transparency from light emitted side,
 - UV protection (in case of sun light exposure),
 - drawing heat away, to keep safe work of circuit,
 - heat produced by LED resistance,
 - low transmission in all climate conditions.

Montage information

1. LED modules must be connected to power supply in accordance with all electric and safe standards. Before switching power on it is always required to check all the electric connections and make sure that power supply has proper electric parameters.
2. It is very important to mount module to the element which helps to draw heat away (e.g. aluminium plate, radiator). In case of montage using screws, some separators (silicone, mica, silicone paste or other material that conduct heat) are needed between radiator and substrate of the module. Such a separator needs to be used, because it helps to transfer heat from the substrate to the radiator and makes LED work conditions better. Module can also be mount to the radiator using special glue or tape, which conduct heat.
3. Depends on the power of power supply it is important to use radiator with proper thermal resistance. When power supply is 1W, radiator should have maximum thermal resistance at a level of 30 K/W, it corresponds e.g. aluminium sheet, 2 mm thickness and 16cm² area (e.g. 4 cm side square).
When power supply is 3W, radiator should have maximum thermal resistance at a level of 7 K/W, it corresponds e.g. aluminium sheet, 2 mm thickness and 100cm² area (e.g. 10 cm side square).
4. LUMO 1XR LED module has 4 big electric pads. Each electrode '+' and '-' has two pads, where positive and negative voltage should be connected. Each of additional pads help to connect LED modules parallel. To solder cables, standard soldering gun is needed.
5. There are examples of LUMO 1XR connections on the next page. It is recommended to drive modules by current, using special current power supplies (example number 2). It is possible to drive modules by voltage using stabilized voltage power supplies with serial resistor (example number 1) or LM317 circuit in current stabilization mode (example number 3). LUMO 1XR modules are adjustable to connecting them parallel (example number 4).
6. Shown schemes are not all possible ways of connecting, they only illustrate how LUMO 1XR modules can be driven. To get more information about LED driving please visit our web page www.lediko.com and see section [Technology](#).

Example number 1 – three serial connected LUMO 1XR modules, drive voltage 12 V.

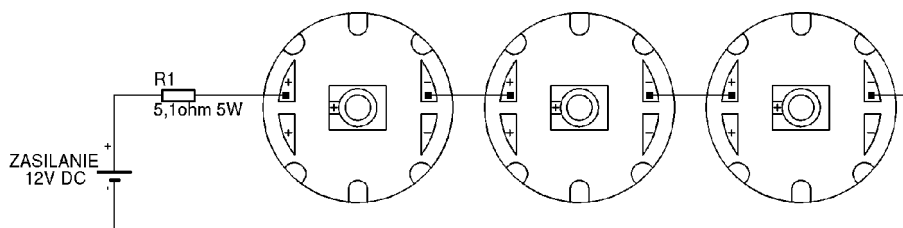

Example number 2 – six LUMO 1XR modules, drive current 350/700 mA.

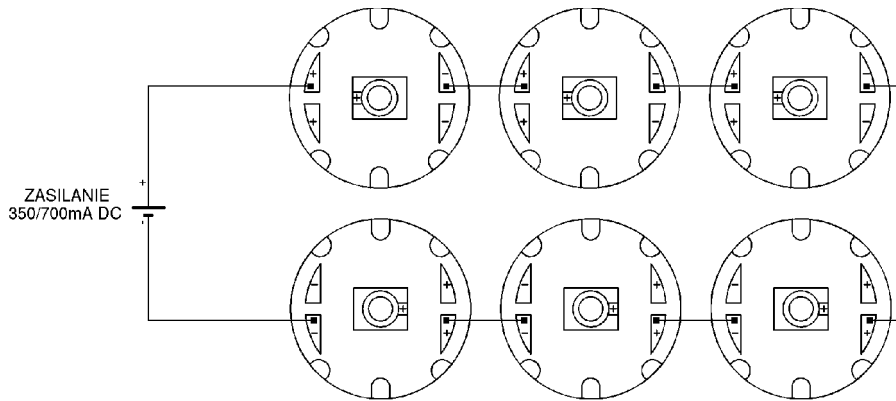

Example number 3 – six LUMO 1XR modules, drive voltage 24 V with LM317T stabilizer.

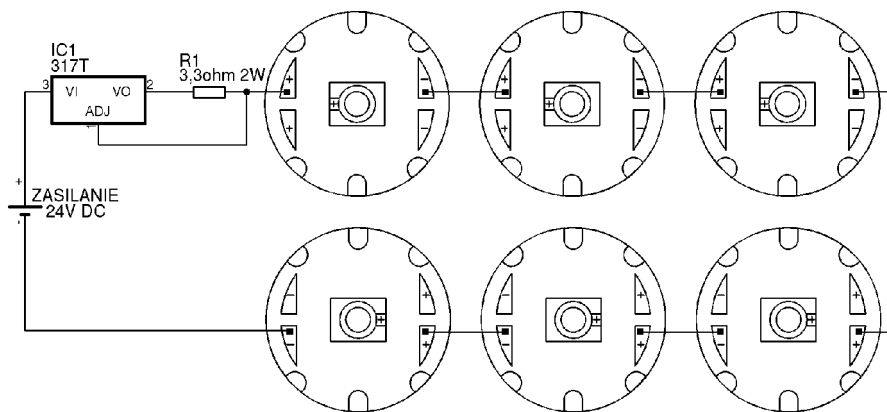

Example number 4 – parallel connection of LUMO 1XR modules, drive voltage 24 V.

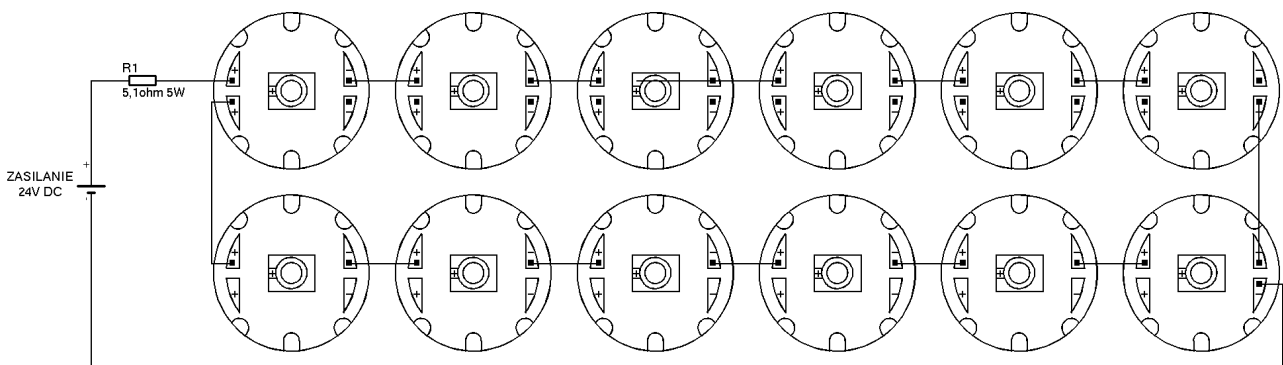

Notice: Values of resistors are selected in a way to achieve 1 W of power on each LED (3,4 V 350 mA). These circuits cannot be used with modules with amber, orange and red colour of LED, because of different drive voltage in those LEDs.

Order particulars

LED module	Colour	Wavelength	Typ. luminous flux (350mA)
LUMO 1XR BLU	Blue	465 – 475 nm	19
LUMO 1XR CYN	Cyan	500 – 510 nm	45
LUMO 1XR GRN	Green	520 – 535 nm	52
LUMO 1XR AMB	Amber	585 – 595 nm	42
LUMO 1XR RDO	Orange - Red	610 – 620 nm	49
LUMO 1XR RED	Red	620 – 635 nm	40

Package Standard package contains 20 LUMO 1XR modules. Modules are in carton box (dimensions: 16,8cm x 13,2cm x 3,0cm). Modules are covered with sponge cover.

When placing an order please write:

- 1) Name and surname of orderer,
- 2) Company name,
- 3) Company Tax Identification Number,
- 4) Address of company or private address for individual customers,
- 5) City and post code,
- 6) Index of elements: number of elements, product code,
- 7) Sending address (if differ from company address).

Welcome to contact us and place orders.

Phone: +48 71 79 85 785

www.lediko.com



Notice: "LEDIKO Walendowski i Wilanowski" Sp.J. stipulate the information in this document is subject to change without notice.